



THE ALL-NEW
VOLVO V60
CROSS COUNTRY



WE'RE VOLVO CARS.

We put people first.

We're Swedish. Scandinavian designers always start with the person who's going to use an object and ask, "What can we do to make this person's life better, easier or more comfortable?" We've always used this philosophy when we design our cars. So, while other car manufacturers might start with technology and try to squeeze people in around it, we begin by designing our cars around you. We ask what you need, and then use our technical skills to make your life easier, better, safer and more beautiful. Form follows function, and when you design a car inside and out with people in mind, it looks naturally beautiful. We think that looking at and interacting with our cars should make you feel great, every day. Designing cars around people has led to many innovations over our

88-year history. You know the three-point safety belt in your current car? That was our invention from 1959. And now we're working towards our vision to design cars that should not crash. In the shorter perspective, our aim is that by 2020 nobody should be killed or seriously injured in a new Volvo. Of course, you'll already benefit from this research in your current Volvo. We've addressed a few environmental issues, too – in 1976, we developed the Lambda Sond – a sensor that monitors exhaust gas, reducing emissions and boosting performance as well as economy. It's still part of every petrol-engined car in the world. Innovation is at the core of Volvo Cars – it's because of where we come from.

Contents

YOUR NEW CAR | 02

INSIDE YOUR CAR | 08

YOUR ADVENTURE | 10

SENSUS | 12

INTELLISAFE | 16

DRIVE-E | 20

EXPRESS YOURSELF | 24

COLOURS | 26

WHEELS | 28

PERSONALISE YOUR INTERIOR | 30

UPHOLSTERIES | 32

ACCESSORIES | 34

FACTS AND FIGURES | 38

THE VOLVO EXPERIENCE | 40



The minute you set eyes on the Volvo V60 Cross Country, you know it means business. The V-shaped bonnet, strong shoulders and falling roofline speak of pace and athleticism. At the same time, rugged design cues add to the car's muscular stance and leave you in no doubt that this car is ready for any adventure.

Yes, this Cross Country sportswagon is a dynamic driver's car, but it also allows you to take everything you need on your weekend away, no matter how remote your destination is. And thanks to the protective design elements of the V60 Cross Country, it's much less vulnerable to scratches and minor damage.

At the heart of the V60 Cross Country's dynamic and capable driving experience is a great chassis. We've spent thousands of hours perfecting and tuning it, and heightened its responsive, in-command driving experience. Then, we added All-Wheel Drive and gave our sportswagon 201mm ground clearance for real all-road, all-weather capability.

When you get behind the wheel, you'll discover another great example of outstanding Swedish people-focused design. Seats have been a strength of Volvo Cars since the 1970s, when we enlisted ergonomic experts to help us develop a supportive shape that ensures you arrive fresh and relaxed after even the longest journey. With the V60 Cross Country, we've been able to give you the same comfort in the shape of a sport seat, as befits a true driver's car.

Then, there's the sheer build quality. You can always tell true craftsmanship by looking at the details. The V60 Cross Country has beautifully styled integrated tailpipes, which are the physical and visual link to our technically advanced, highly efficient new generation of drivetrains.

So if you're looking for a car that not only stands out from the crowd, but is also a perfect companion for you and your family on all roads, the Volvo V60 Cross Country is for you.



*"It's ideal if you have an adventurous lifestyle,
taking you where you want to be, whatever the weather."*

VOLVO V60 CROSS COUNTRY

*Adventure that lives up
to its promise.*

If you're the sort of person who goes out and explores the world, the Volvo V60 Cross Country is the car for you: a sportswagon that not only offers dynamism and versatility, but rugged looks and all-road capability, too. It's ideal if you have an adventurous lifestyle, taking you where you want to be, whatever the weather. And thanks to its loadspace and versatility, you can follow the call of the wild with your children in tow.

Even when it's parked in the driveway, the Volvo V60 Cross Country exudes a sense of

adventure. Its sweeping roof and tapered rear windows give a sense of urgency while its tall, in-command posture and muscular design cues signal a readiness to take on the world. It's the sort of car you spot from a distance – an individualist's choice that stands out from the crowd. After all, your life is out of the ordinary, so why hide in an ordinary car?

The sense of being in control continues on the inside. The minute you sit down in our seats, you feel in complete control, no matter what the road or the weather throws at you.

Once you set off on your journey, the high ground clearance gives you a great overview in town – as well as the capability to leave the city far behind. And when the road gets rough or the weather turns ugly, the All-Wheel Drive variants come into their own, and see you safely to your final destination. No matter where you go, no matter what the season: our Cross Country sportswagon lives up to its promise.



The Volvo V60 Cross Country is a car you spot from a distance. Its high ground clearance helps you being in control in town, as well as the ability to take on rougher roads. It also communicates pride and confidence – and the car's silver roof rails accentuate this stature even further. Take a closer look and you'll find that glossy black detailing on the mirrors and window frames adds another

touch of exclusivity. But the Volvo V60 Cross Country is, above all, a capable, athletic car. With rugged design elements all around, this car challenges you to take it on an adventure, braving the elements and exploring new terrain. In the front, a black honeycomb grille and lower grille moustache in black give it our unique Cross Country "face", which is further enhanced by a front skid plate. Black

wheel-arch extensions make for a wide, muscular stance and continue seamlessly into the distinctive side scuff plates. There's also a rear skid plate, which protects your car from gravel when you leave the tarmac. And the famous Cross Country logotype lets the world know that you're ready for action.



*"We're famous for our seats
– they're a proud tradition for us at Volvo Cars."*



No need to take your hands off your steering wheel as you shift up and down the automatic gearbox in manual mode – just flick through the gears with our optional gearshift paddles. You'll be in total command of your car, with both hands on the wheel. And quicker gear changes give your drive an additional edge when you're in the mood for upping the tempo.



We've designed the cockpit around you, the driver. Get inside and feel in complete command as the dashboard gently angles towards you. We were inspired by high-performance motorbikes when we came up with the idea of a single round instrument flanked by two smaller dials. Then, we carefully sculpted the three-spoke steering with the aim of giving you a very physical sense of connection between your car and the road. But where you sit is even more

important. "We're famous for our seats," says Stefan Sällqvist, "they're another proud tradition for us at Volvo Cars. Our sport seats look fantastic and, true to our unrelenting commitment to ergonomic design, you'll be able to drive for hours sitting in it without getting tired. It also has great side support all the way from your thighs to your shoulders, so the seats keep you firmly in position even when you're cornering fast."

"This is a Volvo for people who don't just talk about adventure, but live it too."



CHASSIS & CAPABILITY

Are those rugged looks for real? Oh, yes.

This is a Volvo for those individuals who live life as a genuine adventure. And the V60 Cross Country doesn't just look the part, it's got the capability to back up that seriously rugged profile. For example, the Cross Country features 201mm of ground clearance, which is a significant 65mm higher than that of our standard V60 – a crucial factor in any vehicle's ability to take on rough terrain or deep snow and mud. And if you choose an All-Wheel Drive variant, you'll have even more capability to carry on when conditions turn difficult.

After all, adventure often takes you to unexplored roads. And when you find yourself facing a particularly challenging hill, the Hill Descent Control helps ensure a safe, smooth and "in-control" ride down – all you need to do is steer.

But this is still a true Volvo, with as much ability on road as off with a suspension that delivers a fine combination of ride and handling. Enthusiastic drivers will also appreciate the Corner Traction Control with Torque Vectoring – this technology enables the V60 Cross Country to turn into corners

with real sporting precision and effectively resists understeer, or the tendency of the front wheels to push wide in tight corners.

So this really is a Volvo for people who don't just talk about adventure, but live it too. For them, all-weather capability and the ability to occasionally leave smooth, well-travelled roads behind is essential. For that, you need a tough, durable partner. And that's really what the V60 Cross Country is all about – not just its rugged good looks, although that's a nice bonus.

"Sensus is about making your interaction with your car intuitive, and ensuring you're on the road, but not offline."

SENSUS

The intuitive way to interact with your car.

Volvo Sensus is our all-encompassing approach that connects you with your car and the world around you. It means you're on the road, but not offline. With Sensus Connect, you can turn the seven-inch screen in your dashboard into an internet-connected infotainment hub. Not only can you surf the web, you can also download apps – from Rdio to Stitcher and Tuneln. Sensus Connect also gives you access to basic internet maps and routing, and to take advantage of navigation guidance, 3-D views and navigation apps, there's our Sensus Navigation option. If you'd like to take your connectivity to the next level, there's Volvo On Call. This option gives you 3G-connectivity with excellent reception

through your car's integrated roof aerial, so you can create a Wi-Fi hotspot for all of your devices. Meanwhile, Connected Service Booking allows you to book your car in for a service from the comfort of the driver's seat.

A high-end audio experience is also part of Sensus. That's why we've designed our state-of-the-art Premium Sound with Harman Kardon®. Using 12 high-fidelity loudspeakers, the amplifier is equipped with Dirac Live®, the next generation sound enhancement software. With an incredibly realistic stage sound as well as enhanced bass performance, this sound system provides an unparalleled aural experience for every passenger and connects easily with external media players.

Our digital driver display is another delight. Not only does it give you all the information you need without overwhelming you – its three background modes, Elegance, Eco, and Performance, also sync with the centre screen. The physical controls, such as our floating centre stack with its iconic 'manikin' climate control buttons, are another example of Swedish design that's both functional and beautiful. And then there's our eye-catching illuminated gearshifter, which is available for selected automatic gearboxes. Glowing gently in the dark, it adds a touch of atmosphere to your night drives.

A special connection. Volvo On Call allows you to connect with your car as never before, while also connecting your car to the outside world.

At its heart is a smartphone app you can use to check on – and interact with – your car no matter where you are. This is very handy if, for example, you want to pre-heat your car in time for your arrival. And to go online, the package includes a built-in modem and dedicated SIM-card slot. Volvo On Call also provides help when you need it most. The On Call button in the cabin puts you through to breakdown services. And in emergencies, the cabin's SOS button provides an instant link to a team of Volvo Car crisis managers. To cover any eventuality, if there are indications that you've had an accident (such as a deployed airbag), we will call you. If there's no response, we'll send the emergency services to you straight away.

READ MORE AT VOLVOCARS.COM

SENSUS



*"Our vision is to design cars
that should not crash."*

INTELLISAFE

Intuitive safety by Volvo Cars. For you, and for those around you.

At Volvo Cars, safety is an intrinsic part of our DNA. We've invented some of the world's most pioneering life-saving technologies – such as the three-point safety belt that's been acknowledged one of the most important innovations of mankind.

But we aim higher. Our vision is to design cars that should not crash. In the shorter perspective the aim is that by 2020 nobody should be killed or seriously injured in a new Volvo.

IntelliSafe is our approach for a more harmonious relationship between cars and people. To achieve this, we have infused your Volvo with smart, intuitive innovations for a safer drive. And the IntelliSafe technologies help protect not only the people inside your car – we also consider people on the outside, for example with technology that helps you to detect pedestrians and cyclists.

When you drive at speeds up to 50 km/h, our City Safety collision avoidance technology looks ahead of you and brakes automatically if you're about to run into a vehicle in front.

To give you more support at higher speeds, our Collision Warning with Auto Brake and Pedestrian and Cyclist Detection alerts you if you're too close to a vehicle and a collision is imminent – day or night. During daylight, the system also reacts if there's a pedestrian in your path or a cyclist ahead travelling in the same direction as your car. And should you not react to the warning, your car brakes automatically to help you avoid or mitigate a collision.

If your car should begin to drift between the lanes, our Lane Departure Warning or Lane Keeping Aid technology will alert you or help you to stay in the lane – there's even Driver Alert technology that reminds you to take a break in case your driving behaviour shows signs of drowsiness.

Our IntelliSafe technologies also support your daily driving. The Road Sign Information technology keeps you updated on actual speed limits and other important road signs. At night, our Active High Beam stays on high beam all the time to optimise your vision

without dazzling other road users. And to make you a bit more relaxed on the road, our Adaptive Cruise Control can maintain your set speed and distance to the vehicle in front. In slow-moving city traffic, our Queue Assist function can automatically maintain the selected distance to the car in front – from standstill and up to 30 km/h. Our BLIS system helps you to early detect other vehicles in your blind spot, while the Cross Traffic Alert function facilitates reversing out of tight parking spaces where your vision can be restricted.

And because we know you love to drive, our active IntelliSafe technologies like Electronic Stability Control add to reassuring driving stability in all conditions without sacrificing the joy of driving. It's simply about giving you the most human driving experience, on your terms. And helping to keep people out of harm's way, whether they happen to be inside or outside your car.

Light up the dark. Driving in the dark just became a lot more enjoyable and safer. Our Active High Beam stays on high beam all the time. You don't have to flick between low and high beam, and when you meet or catch up another vehicle the system shades out only as much of your beam as necessary to avoid dazzling – while you still get the benefit of a brightly lit road. This intelligent technology can even recognise pedestrians and cyclists and avoid dazzling them too. And when you enter a city, the high beam shuts off.

FIND OUT MORE AT VOLVOCARS.COM

INTELLISAFE



In town, City Safety is designed to prevent you from colliding with the car in front if it stops, or slows suddenly. This advanced IntelliSafe system will automatically brake to avoid a crash and works at speeds of up to 50 km/h – an accident can be avoided at a speed difference of up to 15 km/h to the vehicle in front.

Because we also care about other road users, our pedestrian and cyclist detection with full auto brake watches out for people walking in your path or cycling in the same direction as your car and applies the brakes if you're unable to react in time.

Our BLIS system uses radar sensor technology to alert you to vehicles that are close to or in your blind spots in your adjacent lane. This way, you're far less likely to change lanes when it isn't safe.

When you're reversing out of tight parking spaces, our Cross Traffic Alert function watches out for vehicles you can't see.

READ MORE AT VOLVOCARS.COM



“Our commitment to performance at ever lower fuel consumption means that our entire powertrain range will soon consist of a new generation of highly efficient 2.0 litre, four-cylinder engines.”



DRIVE-E

Enjoying more. Using less.

Drive-E isn't just about our new generation of efficient powertrains, it's about our all-embracing approach to sustainable driving. And while we're committed to creating smarter, more innovative technologies to reduce our cars' impact on the environment, we'll never lose sight of the pleasure to be had in driving. In short, we believe you don't need to sacrifice power and superb driveability for efficiency and low CO₂ emissions.

Our Drive-E powertrain range consists of highly efficient 2.0-litre, four cylinder petrol and diesel engines. We've mated these turbocharged, low-friction, light-weight powerplants with Geartronic®, our all-new eight-speed automatic gearbox, which ensures you get optimum performance at any engine speed.

Your Volvo also has an ECO+ function which can reduce fuel consumption by up to five per cent, depending on driving style. ECO+ not only optimises shift points, engine control and throttle response. It also includes a Stop/Start system and an ECO coast function. This disengages the clutch when you release the accelerator at speeds above 65km/h: instead of the engine braking the car and using up fuel in the process, your Volvo will coast along using its kinetic energy.

Our Drive-E diesel powertrains have additional technologies designed to reduce fuel consumption and emissions. Twin turbochargers and the revolutionary i-ART ensure that these intelligent engines provide responsive, clean and efficient performance – each cylinder has its own microchip and

pressure sensor for perfect metering of fuel. Better still, these advanced engines remain in precise tune even after years of use.

Of course, we're committed to a clean environment inside your car as well. As part of CleanZone, all materials in your Volvo's interior are hypo-allergenic and do not emit harmful gases. CleanZone also includes a highly effective dust and pollen filter. You can boost this further with our Interior Air Quality System. This uses an active carbon filter to reduce harmful gases and particles, enabling you and your passengers breathe easy – even in polluted cities.



DRIVE-E

The Volvo V60 Cross Country is available with a wide range of cutting-edge petrol and diesel engines designed to meet your preferences. All of them are designed to offer maximum driving pleasure while using fuel efficiently and keeping CO₂ emissions at a minimum.

The T5 petrol option is available with front-wheel or all-wheel drive, producing 245hp and 254hp respectively, with CO₂ emissions of 155g and 198g. If you prefer diesel, our front-wheel drive D3 puts out 150hp at 111g CO₂*. Then there's our higher performance D4 version, which produces 190hp at 111g CO₂*. It's available both in all-wheel and front-wheel drive.

You can order our diesel variants that are available with both automatic or manual transmissions, except for the D4 AWD version, which comes with automatic transmission as standard.

*Fuel consumption and CO₂-emissions figures apply to manual cars.

READ MORE AT VOLVOCARS.COM



Which V60 Cross Country are you?

Congratulations, you've chosen a Volvo V60 Cross Country. Now you've decided on your preferred engine, all you need to do is select the trim level that's right for you. We've made

it easy for you by providing four that we think you'll love. Whether you'd like all the trimmings or a sporty look both inside and out, we have the right one for you.

V60 CROSS COUNTRY

Includes:

16" steel wheels | 3-point safety belts on all 5 seats with belt reminder | 40/20/40 split rear seat | Airbag, driver & passenger side | AUX input | Charcoal decor inlays | City Safety | Corner Traction Control (CTC) | Dual cup holders, front | Electronic Stability Control (ESC) | Electrically operated parking brake | Electronic Climate Control (ECC) with ventilation outlets in B-pillars | Front seat 12V outlet | Headlamp level adjuster | Illuminated vanity mirror, passenger side | Inflatable Curtains (IC) | ISOFIX, rear | LED DRL (Day Running Light) | Load cover | Mellbystrand textile upholstery | Outer temperature gauge | Remote control central locking | Sensus infotainment with 5" colour screen in the center stack and Performance audiosystem with CD player | Side impact airbags integrated in the front seats | Trip computer | Tyre Pressure Monitoring System (TPMS) | Tyre sealant kit | WHIPS

KINETIC

Includes Base equipment level plus the following:

16" Pangaea aluminium wheels | Audio controls in steering wheel | Cruise control | Illuminated vanity mirror, driver side | Leather-clad gear knob | Leather-clad steering wheel | Textile floor mats | Lock door switch passenger side

MOMENTUM

Includes Kinetic equipment level plus the following:

17" Valder aluminium wheels | Automatically dimmed frameless inner mirror | Bluetooth® | Bright work around side windows | Tylösand textile/T-Tec upholstery | High Performance audio system | Leather-clad steering wheel with silk metal inlay | Metal luggage threshold | Park assist rear | Rain sensor | Retractable rear view mirrors with ground lights | Uni décor climate control "manikin"

SUMMUM

Includes Momentum equipment level plus the following:

18" Neso aluminium wheels | Digital driver display | Leather upholstery | Power driver seat with memory function for seat and side mirrors | Rear armrest with cup holders and storage

The exterior colour you choose has a dramatic impact on the personality of your Volvo. But no matter which you choose, each one imbues the car with a sense of luxury and presence.

“Our colour palette is very Scandinavian,” says Ebba Maria Thunberg, who is responsible for colours and material. “When you look at

our palette, you’ll find that it contains softer tones that are more connected with nature, with a few bold splashes.” Being Swedish, our designers are inspired by the ocean and the sky, but also by the shore and the way the light changes throughout the seasons. Every tone speaks of uniqueness, quality and charisma.



700 Twilight Bronze metallic



614 Ice White



707 Inscription Crystal White Pearl
(Sparkling metallic, shifts from white to shimmering warm yellow-white effect depending on light and viewing angle)



711 Bright Silver metallic



477 Inscription Electric Silver metallic
(Sparkling metallic, shifts from silver to blue effect depending on light and viewing angle)



019 Black Stone



717 Onyx Black metallic



492 Savile Grey metallic



714 Osmium Grey metallic



712 Rich Java metallic

From expressive to discreet, elegant to sporty, you can give your V60 Cross Country a unique twist by the wheels you choose.

Would you like to make an entrance or do you prefer the charm of the understated? Are you going for a sporty persona or an intricate, refined look? Try different wheels on our online configurator and find the one that's right for you.

Neso, 7.5x18"
Diamond Cut/Tech Matte Black



Pan, 7.5x18"
Silver



Bor, 8x19"
Diamond Cut/Matte Black



Pangaea, 7x16"
Silver Stone



Valder, 7.5x17"
Silver

Your V60 Cross Country is your home away from home. Give it your signature.

Choose a V60 Cross Country and you'll enjoy an elegantly designed cabin as standard, with a superior finish in evidence everywhere you look – from the silk metal finish on our air vents to the fine cloth surfaces on the door pillars.

Our Comfort seats can be ordered in Mellbystrand textile, Tylösand T-Tec/textile or leather, while our Sport seats in leather

give you legendary Volvo comfort while also keeping you firmly in place in those fast corners. And for added control, our gearshift paddles allow you to change gears with the flick of a finger whenever you have the optional automatic gearbox in manual mode – so you never have to take your hands off the steering wheel while driving. It's a great feature for added control. You can go one

better by choosing our heated steering wheel, which lets you gently warm your hands in cold conditions. And with our heated windscreen, you'll never have to stand outside scraping ice off the glass in the freezing cold. Once you're in the driver's seat, you'll appreciate the easy-to-read analogue driver display or, if you prefer, our digital driver display.





Sport seat



Comfort seat

INLAYS



Urbane Wood



Brushed aluminium



Shimmer Graphite aluminium



Piano Black

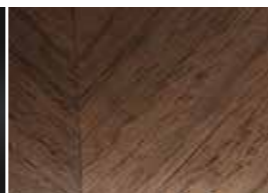

Inscription Linear Walnut



Textile

Textile/T-Tech

Leather

Sport Leather

“With the dog gate, you can open the tailgate without your dog leaping out – which makes life so much easier.”



NO TWO LIVES ARE THE SAME.

Make sure your Volvo matches yours.

The most pleasurable part of buying a new Volvo is putting your personal stamp on it. You can do that by choosing accessories that reflect your own taste and that cater to your particular lifestyle.

For the load compartment in the rear, there's our steel safety grille, which is an alternative to the standard safety net. This gas-sprung steel grille is colour coordinated with your interior and helps to protect you and your passengers from unsecured loads when braking sharply.

And when you don't need it, it folds conveniently up against the roof. Our load

compartment divider is another great accessory. Used together with the steel safety grille, this divides the load compartment into two sections – convenient if you want to carry your dog and luggage, or to separate dirty or fragile cargo from other cargo.

And our new design tow bar is detachable, with a cover for the aperture that maintains the sleek looks of your Cross Country when the hook is not in use.

Our specially designed roof load carriers fit neatly and securely into your car's prepared mounts. They're easy to install and to combine with additional holders if required. And the

roof-mounted bicycle holder is a practical and stable holder for carrying your bike on the roof. It fits most bikes with round or oval frames up to 70mm in diameter. And you can lock it with Volvo One Key System.

Finally, to give your pet a place of its own, you can complement the safety grille and load compartment divider with our dog gate. It allows you to open the tailgate without your dog leaping out – which makes life so much easier.

*"A sophisticated welcome every time
you open the front door."*



Enter your V60 Cross Country in style, everyday. Our illuminated instep plates give you a sophisticated welcome every time you open the front door – the Volvo logo embedded in the brushed stainless steel footstep lights up together with the interior lighting.

And adding our Rear Seat Entertainment system with 8-inch touchscreens and integrated DVD players, your rear seat passengers can watch a film or play games. Wireless headphones ensure a relaxed

journey for everyone inside the car. For your children, we have three Volvo Cars-approved child seats available. Infants of up to one year (or 13 kg) travel safely in our rear-facing infant seat. Side wings give protection in a side impact, and you can easily adjust the padded headrest and five-point harness. There's a canopy to block the sun, too. This infant seat is also easy to carry and can be used as a carrycot.

Our convertible child seat is suitable for children aged nine months to six years

(or 9–25 kg). It's fitted using the car's safety belt and is easily adjusted to help optimise comfort and safety.

Finally, our booster seat helps position children weighing 15–36 kg at the correct height for the safety belt and is designed to optimise side impact protection. The headrest and width adjust easily to enhance comfort, and the backrest can be reclined when your child wants to rest.

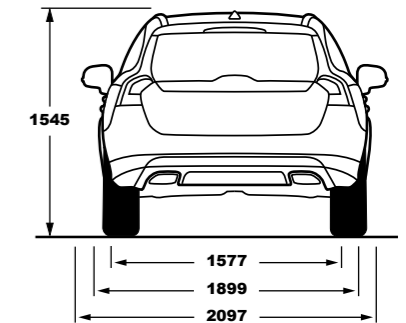
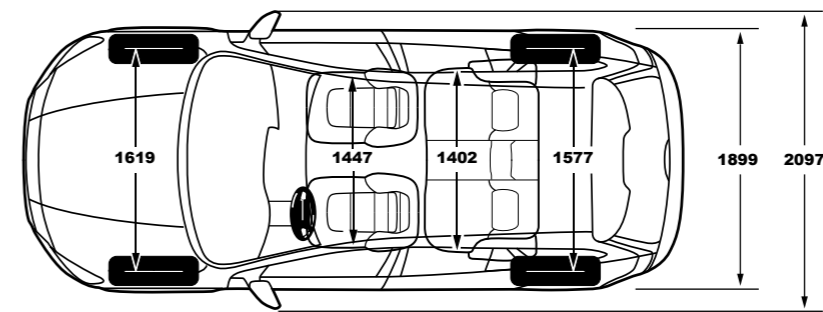
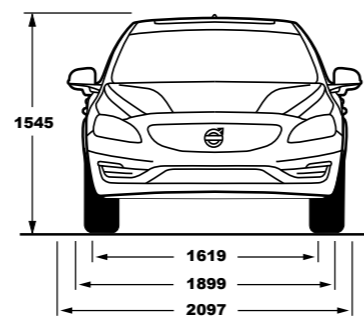
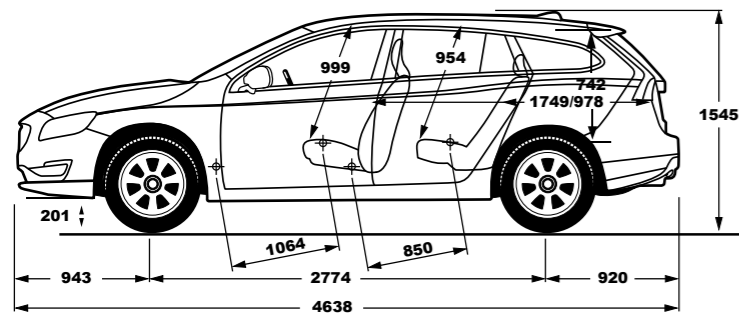

	T5 AWD	T5
Engine type:	2.5L I5 petrol turbo	2.0L I4 petrol turbo
Transmission:	Six-speed Geartronic®	Eight-speed Geartronic®
Fuel consumption, litres/100 km, mixed cycle, man/auto:	-/8.6	-/6.7
CO ₂ g/km, man/auto:	-/198	-/155
Max. power output, kW (hp) at rpm:	187 (254) 5400	180 (245) 5500
Max. torque, Nm at rpm:	360/1800-4200	350/1500-4800
Acceleration, 0-100 km/h in sec, man/auto:	-/7.4	-/6.6
Top speed, km/h, man/auto:	-/210	-/210
Fuel tank, litres:	67.5	67.5
Environmental classification:	Euro 6	Euro 6

	D4 AWD	D4	D3
Engine type:	2.4L I5 common-rail turbodiesel	2.0L I4 common-rail turbodiesel	2.0L I4 common-rail turbodiesel
Transmission:	Six-speed Geartronic®	Six-speed manual or eight-speed Geartronic®	Six-speed manual or eight-speed Geartronic®
Fuel consumption, litres/100 km, mixed cycle, man/auto:	-/5.7	4.3/4.6	4.3/4.6
CO ₂ g/km, man/auto:	-/149	111/121	111/121
Max. power output, kW (hp) at rpm:	140 (190) 4000	140 (190) 4250	110 (150) 4250
Max. torque, Nm at rpm:	420/1500-3000	400/1750-2500	350/1500-2500
Acceleration, 0-100 km/h in sec, man/auto:	-/8.6	7.5/7.5	8.8/8.8
Top speed, km/h, man/auto:	-/210	210/210	205/205
Fuel tank, litres:	67.5	67.5	67.5
Environmental classification:	Euro 6	Euro 6	Euro 6

NB. The engine programme may vary from country to country. All technical data may be subject to change. Please talk to your Volvo Car dealer for the latest information.

Please note: Some of the information in this brochure may be incorrect due to changes in product specifications that may have occurred since printing. Some of the equipment described or shown may now only be available at extra cost. Before ordering, please ask your Volvo Car dealer for the latest information. The manufacturer reserves the right to make changes at any time and without notice to prices, colours, materials, specifications and models.

The simplest way to own a car.

We love it when you're happy. When things are easier than you expect, or go faster and become better. Because when you buy a Volvo, you buy the simplest way to have a car. Financing, insurance, servicing, changing tyres, cleaning – those aspects of car ownership that you might not find very interesting, are the ones that we love to make easier and better for you. That's why your

Volvo Car dealer will always offer you a whole range of simplifying services and offers all designed around you, giving you the most carefree ownership experience possible.

Still, this is just the beginning. Through our uniquely Swedish approach to innovation, we continuously find new ways to make your life simpler. For instance, the Connected Service Booking function, which lets you book an

appointment just by pushing a button in your car. Or the new way of working in teams – like in a racing pit-stop – that is gradually being introduced in Volvo Car workshops all over the world. We call it Volvo Personal Service and it will make your workshop visits much shorter and more convenient. In the future, servicing your car will be so much simpler.

BUYING & OWNING

- Warranties
- Financing
- Leasing
- Insurance
- Service Contract
- My Volvo website

MAINTENANCE & SERVICES

- Volvo Genuine Service
- Rental cars
- Volvo Professional Car Care
- Tyre services

IF SOMETHING HAPPENS

- Volvo Assistance
- Repairs
- Volvo Glass Services
- Volvo Dent Repair
- Car Climate Services

MY VOLVO

My Volvo is a personalised website that contains everything you need to really get to know – and get the most out of – your car. It gives you:

- A complete overview of your Volvo Car ownership
- Easy access to all facts relating to your car
- Personalised offers and exclusive discounts
- Helpful tips regarding your specific Volvo model
- Instructional films and owner's manuals
- Online Service Booking
- Reminders regarding important stages of your car ownership
- Exclusive articles, films and photographs

CONNECTED SERVICE BOOKING*

If your Volvo has Sensus Connect, it will remind you when it needs servicing and offer to contact your Volvo Car dealer for you. Booking proposals sent from your preferred dealer can easily be managed directly in the car or on your personal My Volvo website. When the time comes to drive to your workshop, your Volvo will remind you and even guide you there. And since your Volvo tells us what it needs, we can make sure it always receives the service it requires when it gets there.

* Available depending on introduction date. Please contact your Volvo Car dealer.

V O L V O