



VOLVO S60



WE'RE VOLVO CARS.

We put people first.

We're Swedish. Scandinavian designers always start with the person who's going to use an object and ask, "What can we do to make this person's life better, easier or more comfortable?" We've always used this philosophy when we design our cars. So, while other car manufacturers might start with technology and try to squeeze people in around it, we begin by designing our cars around you. We ask what you need, and then use our technical skills to make your life easier, better, safer and more beautiful. Form follows function, and when you design a car inside and out with people in mind, it looks naturally beautiful. We think that looking at and interacting with our cars should make you feel great, every day. Designing cars around people has led to many innovations over our

88-year history. You know the three-point safety belt in your current car? That was our invention from 1959. And now we're working towards our vision to design cars that should not crash. In the shorter perspective, our aim is that by 2020 nobody should be killed or seriously injured in a new Volvo. Of course, you'll already benefit from this research in your current Volvo. We've addressed a few environmental issues, too – in 1976, we developed the lambda sond – a sensor that monitors exhaust gas, reducing emissions and boosting performance as well as economy. It's still part of every petrol-engined car in the world. Innovation is at the core of Volvo Cars – it's because of where we come from.

Contents

YOUR NEW CAR | 02

INSIDE YOUR CAR | 08

OUR DESIGN VISION | 10

SENSUS | 12

INTELLISAFE | 16

DRIVE-E | 20

EXPRESS YOURSELF | 24

R-DESIGN | 26

COLOURS | 28

WHEELS | 30

PERSONALISE
YOUR INTERIOR | 32

UPHOLSTERIES | 34

ACCESSORIES | 36

FACTS AND FIGURES | 42

THE VOLVO
EXPERIENCE | 44



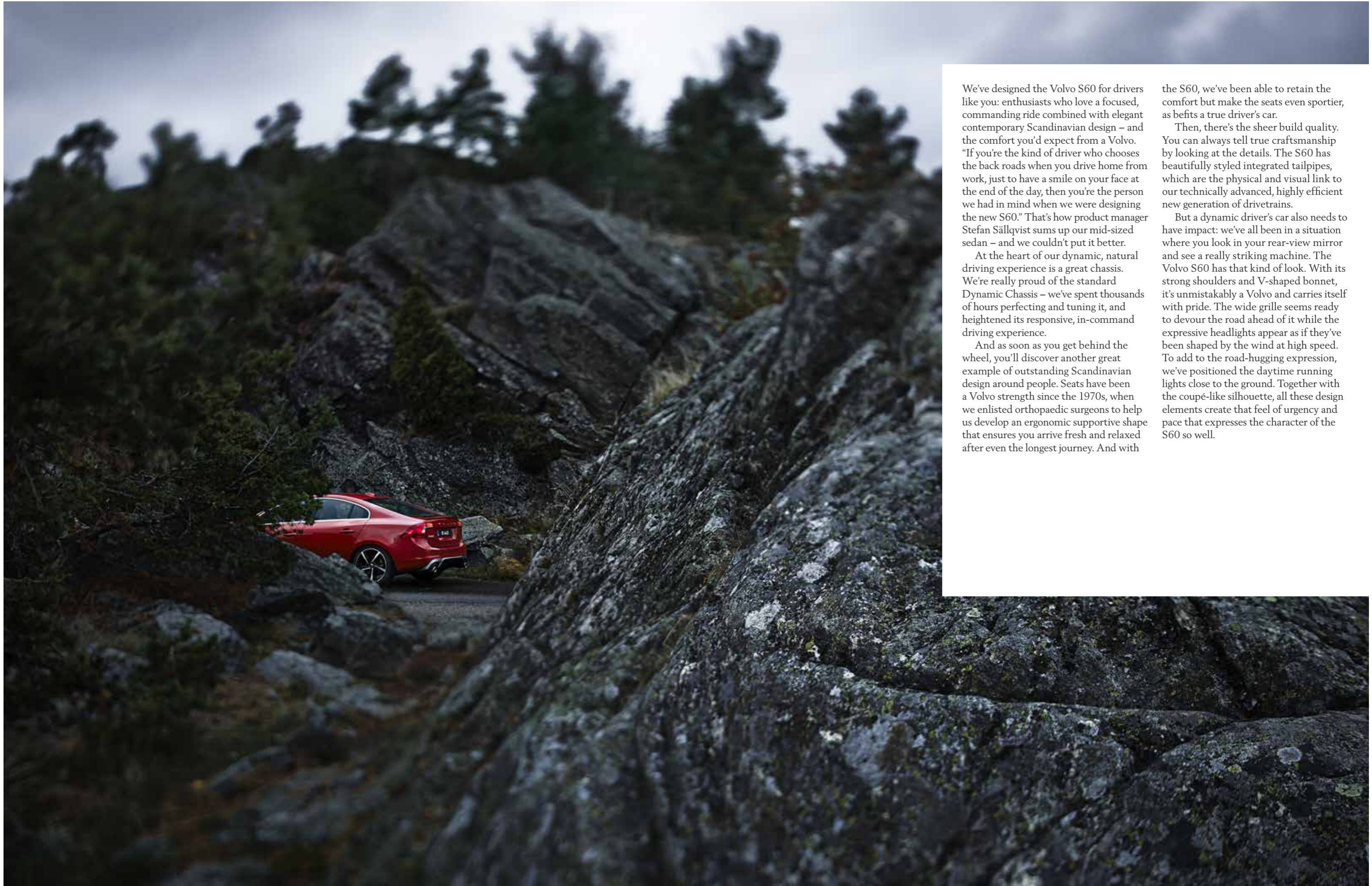

We've designed the Volvo S60 for drivers like you: enthusiasts who love a focused, commanding ride combined with elegant contemporary Scandinavian design – and the comfort you'd expect from a Volvo. "If you're the kind of driver who chooses the back roads when you drive home from work, just to have a smile on your face at the end of the day, then you're the person we had in mind when we were designing the new S60." That's how product manager Stefan Sällqvist sums up our mid-sized sedan – and we couldn't put it better.

At the heart of our dynamic, natural driving experience is a great chassis. We're really proud of the standard Dynamic Chassis – we've spent thousands of hours perfecting and tuning it, and heightened its responsive, in-command driving experience.

And as soon as you get behind the wheel, you'll discover another great example of outstanding Scandinavian design around people. Seats have been a Volvo strength since the 1970s, when we enlisted orthopaedic surgeons to help us develop an ergonomic supportive shape that ensures you arrive fresh and relaxed after even the longest journey. And with

the S60, we've been able to retain the comfort but make the seats even sportier, as befits a true driver's car.

Then, there's the sheer build quality. You can always tell true craftsmanship by looking at the details. The S60 has beautifully styled integrated tailpipes, which are the physical and visual link to our technically advanced, highly efficient new generation of drivetrains.

But a dynamic driver's car also needs to have impact: we've all been in a situation where you look in your rear-view mirror and see a really striking machine. The Volvo S60 has that kind of look. With its strong shoulders and V-shaped bonnet, it's unmistakably a Volvo and carries itself with pride. The wide grille seems ready to devour the road ahead of it while the expressive headlights appear as if they've been shaped by the wind at high speed. To add to the road-hugging expression, we've positioned the daytime running lights close to the ground. Together with the coupé-like silhouette, all these design elements create that feel of urgency and pace that expresses the character of the S60 so well.

"We've boosted the car's handling, design and controls with a comprehensive series of updates that'll have you searching for any excuse to get behind the wheel."

VOLVO S60

For people who enjoy taking the long way home.

The Volvo S60 is a beautifully balanced combination of dynamism, style and comfort. And for 2015, we've given our mid-sized sedan a host of upgrades. In our on-going quest to give you more power at lower fuel consumption, you can now choose from even more variants of our highly efficient Drive-E powertrains, both in petrol and diesel. And with our gearshift paddles you can shift up

and down the optional automatic gearbox in manual mode without ever taking your hand of the steering wheel. Inside, you'll love the sheer comfort of the cabin – especially at night, when it is tastefully lit with Ambient Light. Volvo On Call ensures you're on the road, but not offline: using its built-in modem and dedicated SIM-card slot, you'll be able to browse the web, access apps and use

online navigation. Then, there's Premium Sound by Harman Kardon®, which makes you experience your favourite music in an entirely new way. We've also given you more colours and wheel designs to choose from. All these improvements will have you look for any excuse to get behind the wheel – or admire your S60 when it's parked in the driveway.



When you accelerate
out of a corner...
It's like it can read your mind.

We've focused on the natural driving dynamics so that its actions immediately correspond to your desires.

When you accelerate out of a tight corner, for example, your S60 will follow the path you choose with almost telepathic accuracy. Drivers will love Corner Traction Control, a torque vectoring system that helps you

avoid understeer by applying just the right amount of power and brake force to the inner and the outer wheels as you accelerate out of a corner. You'll find this particularly handy if you're merging into fast moving traffic from a side road.

What's more, a good chassis is the foundation behind any great handling car,

and S60 owners can choose from four individual chassis types: Touring, Dynamic, Four-C and our R-Design Sport chassis. We've spent thousands of hours perfecting and tuning them. We think you'll be thrilled by the result: a responsive, in-command driving experience, whichever option you choose.



*"We're famous for our seats
– they're a proud tradition for us at Volvo Cars."*

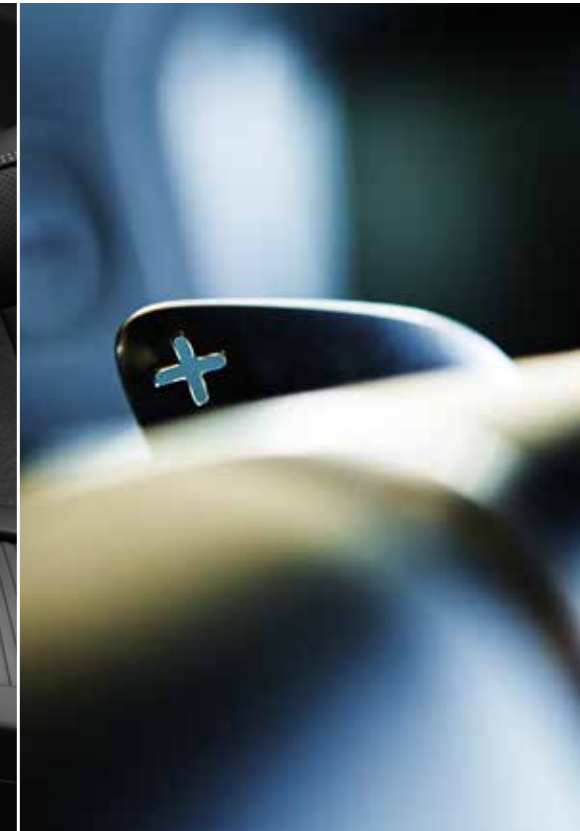

We've designed the cockpit around you, the driver. Get inside and feel in complete command as the dashboard gently angles towards you. We were inspired by high-performance motorbikes when we came up with the idea of a single round instrument flanked by two smaller dials. Then, we carefully sculpted the three-spoke steering with the aim of giving you a very physical sense of connection between your car and the road. But where you sit is even more important.

"We're famous for our seats," says Stefan Sällqvist, "they're another proud tradition for us at Volvo Cars. Our sport seats look fantastic and, true to our unrelenting commitment to ergonomic design, you'll be able to drive for hours sitting in it without getting tired. It also has great side support all the way from your thighs to your shoulders, so the seats keep you firmly in position even when you're cornering fast."

No need to take your hands off your steering wheel as you shift up and down the automatic gearbox in manual mode – just flick through the gears with our optional gearshift paddles. You'll be in total command of your car, with both hands on the wheel. And quicker gear changes give your drive an additional edge when you're in the mood for upping the tempo.

"The car has a beauty that – as with much of contemporary Scandinavian design – is rooted in the natural world."

SCANDINAVIAN DESIGN:

Yes, it looks as good as it performs.

You know when you're driving on a highway; you look in your rear view mirror and see a really striking car's "face" approaching you? That's the Volvo S60.

"The road presence comes from its focused and determined-looking headlights," explains our senior exterior designer Peter Reuterberg. "We were thinking of a wolf's

eyes when we designed the car's 'face'. The S60 has a confident, focused expression, like a powerful animal." The scalloped surfaces on the bonnet accentuate the classic Volvo V-shape with a purposeful frown running right down to the headlamps. The car has a beauty that – as with much of contemporary Scandinavian design – is rooted in the

natural world. "Those clean surfaces and contours give it a very Scandinavian feel," says Reuterberg. The strong shoulders are another unmistakable Volvo design cue – as is the expressive grille with the iconic Volvo diagonal. They enhance the car's self-confident look and tell the world it's proud to be a Volvo.

"Sensus is about making your interaction with your car intuitive, and ensuring you're on the road, but not offline."

SENSUS

The intuitive way to interact with your car.

Volvo Sensus is our all-encompassing approach that connects you with your car and the world around you. It means you're on the road, but not offline. With Sensus Connect, you can turn the seven-inch screen in your dashboard into an internet-connected infotainment hub. Not only can you surf the web, you can also download apps – from Rdio to Stitcher and Tuneln. Sensus Connect also gives you access to basic internet maps and routing, and to take advantage of navigation guidance, 3-D views and navigation apps, there's our Sensus Navigation option. If you'd like to take your connectivity to the next level, there's Volvo On Call. This option gives you 3G-connectivity with excellent reception

through your car's integrated roof aerial, so you can create a Wi-Fi hotspot for all of your devices. Meanwhile, Connected Service Booking allows you to book your car in for a service from the comfort of the driver's seat.

A high-end audio experience is also part of Sensus. That's why we've designed our state-of-the-art Premium Sound with Harman Kardon®. Using 12 high-fidelity loudspeakers, the amplifier is equipped with Dirac Live®, the next generation sound enhancement software. With an incredibly realistic stage sound as well as enhanced bass performance, this sound system provides an unparalleled aural experience for every passenger and connects easily with external media players.

Our digital driver display is another delight. Not only does it give you all the information you need without overwhelming you – its three background modes, Elegance, Eco, and Performance, also sync with the centre screen. The physical controls, such as our floating centre stack with its iconic 'manikin' climate control buttons, are another example of Swedish design that's both functional and beautiful. And then there's our eye-catching illuminated gearshifter, which is available for selected automatic gearboxes. Glowing gently in the dark, it adds a touch of atmosphere to your night drives.



SENSUS

A special connection. Volvo On Call allows you to connect with your car as never before, while also connecting your car to the outside world.

At its heart is a smartphone app you can use to check on – and interact with – your car no matter where you are. This is very handy if, for example, you want to pre-heat your car in time for your arrival. And to go online, the package includes a built-in modem and dedicated SIM-card slot. Volvo On Call also provides help when you need it most. The On Call button in the cabin puts you through to breakdown services. And in emergencies, the cabin's SOS button provides an instant link to a team of Volvo Car crisis managers. To cover any eventuality, if there are indications that you've had an accident (such as a deployed airbag), we will call you. If there's no response, we'll send the emergency services to you straight away.

READ MORE AT VOLVOCARS.COM

*"Our vision is to design cars
that should not crash."*

INTELLISAFE

Intuitive safety by Volvo Cars. For you, and for those around you.

At Volvo Cars, safety is an intrinsic part of our DNA. We've invented some of the world's most pioneering life-saving technologies – such as the three-point safety belt that's been acknowledged one of the most important innovations of mankind.

But we aim higher. Our vision is to design cars that should not crash. In the shorter perspective the aim is that by 2020 nobody should be killed or seriously injured in a new Volvo.

IntelliSafe is our approach for a more harmonious relationship between cars and people. To achieve this, we have infused your Volvo with smart, intuitive innovations for a safer drive. And the IntelliSafe technologies help protect not only the people inside your car – we also consider people on the outside, for example with technology that helps you to detect pedestrians and cyclists.

When you drive at speeds up to 50 km/h, our City Safety collision avoidance technology looks ahead of you and brakes automatically if you're about to run into a vehicle in front.

To give you more support at higher speeds, our Collision Warning with Auto Brake and Pedestrian and Cyclist Detection alerts you if you're too close to a vehicle and a collision is imminent – day or night. During daylight, the system also reacts if there's a pedestrian in your path or a cyclist ahead travelling in the same direction as your car. And should you not react to the warning, your car brakes automatically to help you avoid or mitigate a collision.

If your car should begin to drift between the lanes, our Lane Departure Warning or Lane Keeping Aid technology will alert you or help you to stay in the lane – there's even Driver Alert technology that reminds you to take a break in case your driving behaviour shows signs of drowsiness.

Our IntelliSafe technologies also support your daily driving. The Road Sign Information technology keeps you updated on actual speed limits and other important road signs. At night, our Active High Beam stays on high beam all the time to optimise your vision

without dazzling other road users. And to make you a bit more relaxed on the road, our Adaptive Cruise Control can maintain your set speed and distance to the vehicle in front. In slow-moving city traffic, our Queue Assist function can automatically maintain the selected distance to the car in front – from standstill and up to 30 km/h. Our BLIS system helps you to early detect other vehicles in your blind spot, while the Cross Traffic Alert function facilitates reversing out of tight parking spaces where your vision can be restricted.

And because we know you love to drive, our active IntelliSafe technologies like Electronic Stability Control add to reassuring driving stability in all conditions without sacrificing the joy of driving. It's simply about giving you the most human driving experience, on your terms. And helping to keep people out of harm's way, whether they happen to be inside or outside your car.

Light up the dark. Driving in the dark just became a lot more enjoyable and safer. Our Active High Beam stays on high beam all the time. You don't have to flick between low and high beam, and when you meet or catch up another vehicle the system shades out only as much of your beam as necessary to avoid dazzling – while you still get the benefit of a brightly lit road. This intelligent technology can even recognise pedestrians and cyclists and avoid dazzling them too. And when you enter a city, the high beam shuts off.

FIND OUT MORE AT VOLVOCARS.COM

INTELLISAFE



In town, City Safety is designed to prevent you from colliding with the car in front if it stops, or slows suddenly. This advanced IntelliSafe system will automatically brake to avoid a crash and works at speeds of up to 50 km/h – an accident can be avoided at a speed difference of up to 15 km/h to the vehicle in front.

Because we also care about other road users, our pedestrian and cyclist detection with full auto brake watches out for people walking in your path or cycling in the same direction as your car and applies the brakes if you're unable to react in time.

Our BLIS system uses radar sensor technology to alert you to vehicles that are close to or in your blind spots in your adjacent lane. This way, you're far less likely to change lanes when it isn't safe.

When you're reversing out of tight parking spaces, our Cross Traffic Alert function watches out for vehicles you can't see.

READ MORE AT VOLVOCARS.COM



“Our commitment to performance at ever lower fuel consumption means that our entire powertrain range will soon consist of a new generation of highly efficient 2.0 litre, four-cylinder engines.”



DRIVE-E

Enjoying more. Using less.

Drive-E isn't just about our new generation of efficient powertrains, it's about our all-embracing approach to sustainable driving. And while we're committed to creating smarter, more innovative technologies to reduce our cars' impact on the environment, we'll never lose sight of the pleasure to be had in driving. In short, we believe you don't need to sacrifice power and superb driveability for efficiency and low CO₂ emissions.

Our Drive-E powertrain range consists of highly efficient 2.0-litre, four cylinder petrol and diesel engines. We've mated these turbocharged, low-friction, light-weight powerplants with Geartronic®, our all-new eight-speed automatic gearbox, which ensures you get optimum performance at any engine speed.

Your Volvo also has an ECO+ function which can reduce fuel consumption by up to five per cent, depending on driving style. ECO+ not only optimises shift points, engine control and throttle response. It also includes a Stop/Start system and an ECO coast function. This disengages the clutch when you release the accelerator at speeds above 65km/h: instead of the engine braking the car and using up fuel in the process, your Volvo will coast along using its kinetic energy.

Our Drive-E diesel powertrains have additional technologies designed to reduce fuel consumption and emissions. Twin turbochargers and the revolutionary i-ART ensure that these intelligent engines provide responsive, clean and efficient performance – each cylinder has its own microchip and

pressure sensor for perfect metering of fuel. Better still, these advanced engines remain in precise tune even after years of use.

Of course, we're committed to a clean environment inside your car as well. As part of CleanZone, all materials in your Volvo's interior are hypo-allergenic and do not emit harmful gases. CleanZone also includes a highly effective dust and pollen filter. You can boost this further with our Interior Air Quality System. This uses an active carbon filter to reduce harmful gases and particles, enabling that you and your passengers breathe easy – even in polluted cities.

DRIVE-E

The Volvo S60 is available with a wide range of cutting-edge petrol and diesel engines designed to meet your preferences. All of them are designed to offer maximum driving pleasure while using fuel efficiently and keeping CO₂ emissions at a minimum.

Is fuel economy your priority? Then choose our 120hp D2 engine, which consumes just 3.7l/100km and emits 96g CO₂/km. And if you want a high performance diesel option, there's our 225hp D5 engine. Meanwhile, our petrol offer ranges from the 152hp T3 engine to our highly efficient, super- and turbo-charged T6 powerplant, which puts out 306hp at 149g CO₂ emissions.

Fuel consumption and CO₂-emissions figures apply to manual cars.

READ MORE AT VOLVOCARS.COM



Which S60 are you?

Congratulations, you've chosen a Volvo S60. You've even picked your preferred engine. Now all you need to do is select the trim level that's right for you. We've made it easy

for you by providing four that we think you'll love. Whether you'd like all the trimmings or a sporty look both inside and out, we have the right one for you.

S60

Includes:

16" steel wheels | 3-point safety belts on all 5 seats with belt reminder | 40/60 split rear seat | Airbag, driver & passenger side | AUX input | Charcoal decor inlays | City Safety | Corner Traction Control (CTC) | Dual cup holders, front | Electronic Stability Control (ESC) | Electrically operated parking brake | Electronic Climate Control (ECC) with ventilation outlets in B-pillars | Front seat 12V outlet | Headlamp level adjuster | Illuminated vanity mirror, passenger side | Inflatable Curtains (IC) | ISOFIX, rear | LED DRL (Daytime Running Light) | Load cover | Mellbystrand textile upholstery | Outer temperature gauge | Remote control central locking | Sensus infotainment with 5" colour screen in the centre stack and Performance audiosystem with CD player | Side impact airbags integrated in the front seats | Trip computer | Tyre sealant kit | Tyre Pressure Monitoring System (TPMS) | WHIPS (whiplash protection integrated in the front seats)

KINETIC

Includes Base equipment level plus the following:

16" Hera aluminium wheels | Audio controls in steering wheel | Cruise control | Illuminated vanity mirror, driver side | Leather-clad gear knob | Leather-clad steering wheel | Textile floor mats | Lock door switch passenger side

MOMENTUM

Includes Kinetic equipment level plus the following:

17" Pandora aluminium wheels | Automatically dimmed frameless inner mirror | Bluetooth® | Bright work around side windows | Tylösand textile/T-Tec upholstery | High Performance audio system | Leather-clad steering wheel with silk metal inlay | Park assist rear | Rain sensor | Retractable rear view mirrors with ground lights | Shimmer Graphite Aluminium decor inlays | Uni decor climate control manikin

SUMMUM

Includes Momentum equipment level plus the following:

17" Rex aluminium wheels | Digital driver display | Leather upholstery | Power driver seat with memory function for seat and side mirrors | Rear armrest with cup holders and storage | Chrome front

R-DESIGN

Can be added to Kinetic, Momentum, or Summum equipment levels.

18" Ixion aluminium wheels | 3-spoke perforated leather-clad steering wheel with metal R-Design badge | Digital driver display with R-Design theme | Dual exhaust with visible tailpipes | Inscription charcoal headliner | LED dayrunning lights (R-Design) | Leather-clad sport gear knob | Nubuck textile/leather upholstery | R-Design interior decor trim | Rear-view mirror caps in silver metallic finish | Sport chassis | Sport floor mats | Sport pedals | Sport seats | Stainless steel treadplates with R-Design logo | Unique R-Design front design | Unique R-Design rear diffuser

R-DESIGN



“Our optional R-Design Sport chassis has been lowered and stiffened for even better cornering – meaning you’ll enjoy the thrill of driving your S60 even more.”



The R-Design story continues in the interior, starting with supportive sport seats in Nubuck textile and leather. Also included is an exclusive R-Design steering wheel as well as sport pedals. A gear shifter gaiter with contrasting stitching, our unique blue R-Design digital driver display, interior LED lighting and a striking Inscription charcoal headliner all add to the R-Design experience.



Would you like to enhance the dynamic personality of your S60 even further? Well then, R-Design is for you, with a range of features to give your Volvo a sporty, unique profile. But R-Design is so much more than a cosmetic exercise – as with all the best Scandinavian design, form follows function. So, for example, our optional R-Design Sport chassis has been lowered and stiffened for even better cornering – meaning you’ll enjoy the thrill of driving your S60 even more.

For an exterior with a more individual, sporty look, R-Design offers gorgeously sculpted alloy wheels and unique door mirror covers in silver metallic. At the back, a motorsport-style diffuser enhances your car’s dynamic presence, while the R-Design chrome dual exhaust pipes add the perfect finishing touch to the exterior of your S60.

The exterior colour you choose has a dramatic impact on the personality of your Volvo. But no matter which you choose, each one imbues the car with a sense of luxury and presence.

"Our colour palette is very Scandinavian," says Ebba Maria Thunberg, who is responsible for colours and material. "When you look at

our palette, you'll find that it contains softer tones that are more connected with nature, with a few bold splashes." Being Swedish, our designers are inspired by the ocean and the sky, but also by the shore and the way the light changes throughout the seasons. Every tone speaks of uniqueness, quality and charisma.



614 Ice White
(Also available for R-Design)



707 Inscription Crystal White Pearl
(Sparkling metallic, shifts from white to shimmering warm yellow-white effect depending on light and viewing angle)
(Also available for R-Design)



711 Bright Silver metallic



467 Magic Blue metallic



477 Inscription Electric Silver metallic
(Sparkling metallic, shifts from silver to blue effect depending on light and viewing angle)
(Also available for R-Design)



713 Power Blue metallic
(Also available for R-Design)



019 Black Stone



487 Inscription Ember Black metallic
(Sparkling metallic, shifts from black to brown effect depending on light and viewing angle)



717 Onyx Black metallic
(Also available for R-Design)



492 Savile Grey metallic
(Also available for R-Design)



714 Osmium Grey metallic
(Also available for R-Design)



484 Seashell metallic



702 Flamenco Red metallic



612 Passion Red
(Also available for R-Design)



Pallene, 7x17"
Silver



Artio, 8x19"
Diamond Cut/Matte Tech Black



Rex, 7x17"
Silver Bright



Freja, 8x18"
Diamond Cut/Light Grey



Modin, 8x18"
Diamond Cut/Glossy Black or
Diamond Cut/Matte Iron Stone or
Diamond Cut/Matte Terra Bronze



Sadia, 8x17"
Silver



Portia, 8x19"
Top Cut/Silver Bright



Ymir, 8x18"
Diamond Cut/Glossy Black



Portia, 8x19"
Diamond Cut/Glossy Black



Ixion, 8x18"
Diamond Cut/Dark Grey
(R-Design)



Hera, 7x16"
Silver



Inscription Bor, 8x19"
Diamond Cut/Matte Tech Black



Titania, 8x18"
Diamond Cut/Glossy Black



Skadi, 8x18"
Silver Bright



From expressive to discreet, elegant to sporty, you can give your S60 a unique twist by the wheels you choose.

Would you like to make an entrance or do you prefer the charm of the understated? Are you going for a sporty persona or an intricate, refined look? Try different wheels on our online configurator and find the one that's right for you.

Ixion II, 8x19"
Diamond Cut/Matte Black
(R-Design)

Your S60 is your home away from home. Give it your signature.

Choose a S60 and you'll enjoy an elegantly designed cabin as standard, with a superior finish in evidence everywhere you look – from the silk metal finish on our air vents to the fine cloth surfaces on the door pillars.

Our Comfort seats can be ordered in Mellbystrand textile, Tylösand T-Tec/textile or leather, while our Sport seats in leather give you legendary Volvo comfort while

also keeping you firmly in place in those fast corners. And for added control, our gearshift paddles allow you to change gears with the flick of a finger whenever you have the optional automatic gearbox in manual mode – so you never have to take your hands off the steering wheel while driving. It's a great feature for added control. You can go one better by choosing our heated

steering wheel, which lets you gently warm your hands in cold conditions. And with our heated windscreen, you'll never have to stand outside scraping ice off the glass in the freezing cold. Once you're in the driver's seat, you'll appreciate the easy-to-read analogue driver display or, if you prefer, our digital driver display.





Sport seat



Comfort seat

INLAYS



Urbane Wood



Brushed aluminium



Shimmer Graphite aluminium



Piano Black



R-Design



Textile

Textile / T-Tech

Leather

Sport Leather

R-Design Textile / Perforated Leather

R-Design Leather / Perforated Leather

"Our park assist camera, front blind view allows you to 'see around corners' as you negotiate tight exits."

NO TWO LIVES ARE THE SAME.

Make sure your Volvo matches yours.

The most pleasurable part of buying a new Volvo is putting your personal stamp on it. You can do that by choosing accessories that reflect your own taste and that cater to your particular lifestyle.

There's nothing more challenging than trying to negotiate tight exits and junctions with restricted visibility. Our park assist camera, front blind view, takes the stress out of these situations. It allows you to "see around corners" with a 180° field of vision to the left and right in front of you. The image is projected onto your seven-inch centre display so you know exactly who, or what, is approaching.

Our park assist camera, rear does the same job when you reverse. It's mounted in the boot lid and dramatically increases your field of vision behind the car. The image is projected onto your centre display, so you can spot any low obstructions when manoeuvring. There's also a zoom-in view you can use to hitch up a trailer to your towbar. It's so good, you might even start to enjoy the situations you used to dread.

For your children, we have three Volvo Cars-approved child seats available. Infants of up to one year (or 13kg) travel safely in our rear-facing infant seat. Side wings give protection in a side impact, and you can easily adjust the padded headrest and

five-point harness. There's a canopy to block the sun, too. This infant seat is also easy to carry and can be used as a carrycot.

Our convertible child seat is suitable for children aged nine months to six years (or 9–25kg). It's fitted using the car's safety belt and is easily adjusted to help optimise comfort and safety.

Finally, our booster seat helps position children weighing 15–36kg at the correct height for the safety belt and is designed to optimise side impact protection. The headrest and width adjust easily to enhance comfort, and the backrest can be reclined when your child wants to rest.



To reinforce the dynamic stance of your S60, you can customise it with our **Exterior Styling Accessories**, which are available in matte Terra Bronze, matte Silver or matte Iron Stone.

Our eye-catching front skid plate gives your S60 an even more purposeful look, with a metallic finish that's beautifully accentuated as it catches the light. The side scuff plates emphasise the sleek, coupé-like lines, visually connecting it close to the road. The rear skid plates with beautifully sculpted double integrated tailpipes boldly underline the sporty character.

READ MORE AT VOLVOCARS.COM



“Our Rear Seat Entertainment system with 8-inch touchscreens and integrated DVD players can operate independently.”



Since there can only be one driver at a time, the S60 also offers some premium amusements for your rear seat passengers. Our Rear Seat Entertainment system with 8-inch touchscreens and integrated DVD players can operate independently. Wireless headphones are standard (you can also plug in your own wired headphones), so one's game doesn't fight with another one's movie.

And adding our illuminated instep plates, you'll enjoy a sophisticated welcome every time you open the front door and enter your S60 – the Volvo logo embedded in the brushed stainless steel footstep lights up together with the interior lighting.

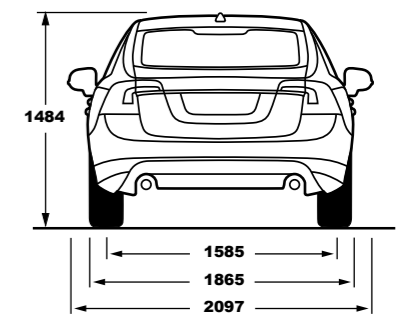
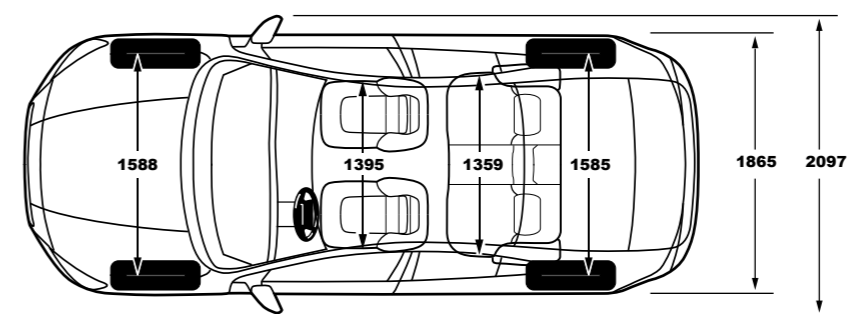
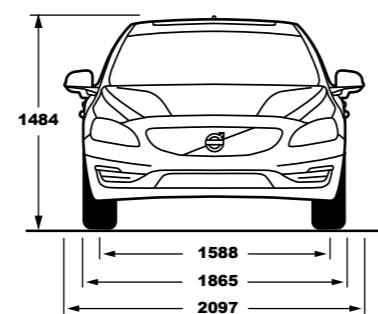
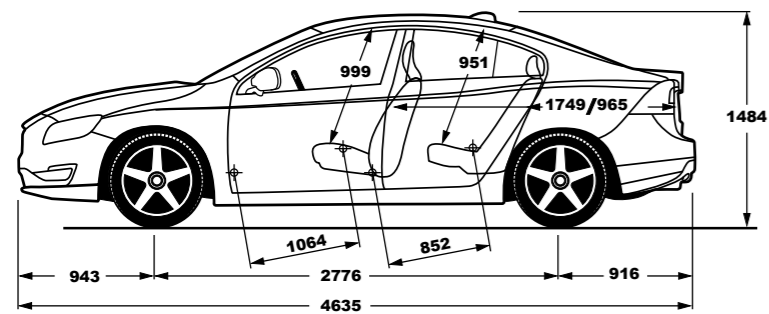

	T6	T5	T4
Engine type:	2.0L I4 petrol supercharged/turbo	2.0L I4 petrol turbo	2.0L I4 petrol turbo
Transmission:	Eight-speed Geartronic®	Eight-speed Geartronic®	Six-speed manual or six-speed Geartronic®
Fuel consumption, litres/100 km, mixed cycle, man/auto:	~6.4	~6.2	5.6/5.8
CO ₂ g/km, man/auto:	~149	~145	131/134
Max. power output, kW (hp) at rpm:	225 (306) 5700	180 (245) 5500	140 (190) 4700
Max. torque, Nm at rpm:	400/2100-4800	350/1500-4800	300/1300-4000
Acceleration, 0-100 km/h in sec, man/auto:	~5.9	~6.3	7.2/7.2
Top speed, km/h, man/auto:	~230	~230	230/230
Fuel tank, litres:	67.5	67.5	67.5
Environmental classification:	Euro 6	Euro 6	Euro 6

	T3	T3
Engine type:	2.0L I4 petrol turbo	1.5L I4 petrol turbo
Transmission:	Six-speed manual	Six-speed Geartronic®
Fuel consumption, litres/100 km, mixed cycle, man/auto:	5.6/-	~5.8
CO ₂ g/km, man/auto:	131/-	~135
Max. power output, kW (hp) at rpm:	112 (152) 5000	112 (152) 5000
Max. torque, Nm at rpm:	250/1300-4000	250/1700-4000
Acceleration, 0-100 km/h in sec, man/auto:	8.6/-	~8.6
Top speed, km/h, man/auto:	210/-	~210
Fuel tank, litres:	67.5	67.5
Environmental classification:	Euro 6	Euro 6

	D5	D4 AWD
Engine type:	2.0L I4 common-rail twin-turbodiesel	2.4L I5 common-rail turbodiesel
Transmission:	Eight-speed Geartronic®	Six-speed Geartronic®
Fuel consumption, litres/100 km, mixed cycle, man/auto:	~4.5	~5.4
CO ₂ g/km, man/auto:	~119	~143
Max. power output, kW (hp) at rpm:	165 (225) 4250	140 (190) 4000
Max. torque, Nm at rpm:	470/1750-2500	420/1500-3000
Acceleration, 0-100 km/h in sec, man/auto:	~6.4	~8.8
Top speed, km/h, man/auto:	~230	~230
Fuel tank, litres:	67.5	67.5
Environmental classification:	Euro 6	Euro 6

	D4	D3	D2
Engine type:	2.0L I4 common-rail turbodiesel	2.0L I4 common-rail turbodiesel	2.0L I4 common-rail turbodiesel
Transmission:	Six-speed manual or eight-speed Geartronic®	Six-speed manual or six-speed Geartronic®	Six-speed manual or six-speed Geartronic®
Fuel consumption, litres/100 km, mixed cycle, man/auto:	3.8/4.1	3.8/4.1	3.7/4.1
CO ₂ g/km, man/auto:	99/109	99/107	96/107
Max. power output, kW (hp) at rpm:	140 (190) 4250	110 (150) 3750	88 (120) 3750
Max. torque, Nm at rpm:	400/1750-2500	320/1750-3000	280/1500-2250
Acceleration, 0-100 km/h in sec, man/auto:	7.6/7.6	9.0/9.0	11.2/11.4
Top speed, km/h, man/auto:	230/230	215/215	195/195
Fuel tank, litres:	67.5	67.5	67.5
Environmental classification:	Euro 6	Euro 6	Euro 6

NB. The engine programme may vary from country to country. All technical data may be subject to change. Please talk to your Volvo Car dealer for the latest information.

Polestar Performance software. Upgrade your car's performance with Polestar Performance software. Polestar are our racing partners. We've been using their expertise on the track to help us continually improve our engines' efficiency and performance.

FIND OUT MORE AT [POLESTAR.COM](https://www.polestar.com)

Please note: Some of the information in this brochure may be incorrect due to changes in product specifications that may have occurred since printing. Some of the equipment described or shown may now only be available at extra cost. Before ordering, please ask your Volvo Car dealer for the latest information. The manufacturer reserves the right to make changes at any time and without notice to prices, colours, materials, specifications and models.

The simplest way to own a car.

We love it when you're happy. When things are easier than you expect, or go faster and become better. Because when you buy a Volvo, you buy the simplest way to have a car. Financing, insurance, servicing, changing tyres, cleaning – those aspects of car ownership that you might not find very interesting, are the ones that we love to make easier and better for you. That's why your

Volvo Car dealer will always offer you a whole range of simplifying services and offers all designed around you, giving you the most carefree ownership experience possible.

Still, this is just the beginning. Through our uniquely Swedish approach to innovation, we continuously find new ways to make your life simpler. For instance, the Connected Service Booking function, which lets you book an

appointment just by pushing a button in your car. Or the new way of working in teams – like in a racing pit-stop – that is gradually being introduced in Volvo Car workshops all over the world. We call it Volvo Personal Service and it will make your workshop visits much shorter and more convenient. In the future, servicing your car will be so much simpler.

BUYING & OWNING

- Warranties
- Financing
- Leasing
- Insurance
- Service Contract
- My Volvo website

MAINTENANCE & SERVICES

- Volvo Genuine Service
- Rental cars
- Volvo Professional Car Care
- Tyre services

IF SOMETHING HAPPENS

- Volvo Assistance
- Repairs
- Volvo Glass Services
- Volvo Dent Repair
- Car Climate Services

MY VOLVO

My Volvo is a personalised website that contains everything you need to really get to know – and get the most out of – your car. It gives you:

- A complete overview of your Volvo Car ownership
- Easy access to all facts relating to your car
- Personalised offers and exclusive discounts
- Helpful tips regarding your specific Volvo model
- Instructional films and owner's manuals
- Online Service Booking
- Reminders regarding important stages of your car ownership
- Exclusive articles, films and photographs

CONNECTED SERVICE BOOKING*

If your Volvo has Sensus Connect, it will remind you when it needs servicing and offer to contact your Volvo Car dealer for you. Booking proposals sent from your preferred dealer can easily be managed directly in the car or on your personal My Volvo website. When the time comes to drive to your workshop, your Volvo will remind you and even guide you there. And since your Volvo tells us what it needs, we can make sure it always receives the service it requires when it gets there.

* Available depending on introduction date. Please contact your Volvo Car dealer.

V O L V O